

PREMIER

THE ORIGINAL SOURCE / THE ORIGINAL DESIGN

Hydraulic Earth Auger Attachments

OPERATOR'S MANUAL

Models:

H075PD and H085PD

and H095PD

Serial Number _____

Model Number _____



WARNING! Avoid injury or death. Read and understand this entire manual before installing, operating or servicing this equipment.

TABLE OF CONTENTS

To The Owner	2
Warranty Registration Form	3 – 4
Warranty Policy	5
Safety Information	6 – 7
Skid Steer Loader Installation Instructions	8
Backhoe & Excavator Installation Instructions	9
Hydraulic Hookup Instructions	10
Operating Instructions	11
Maintenance Instructions	12
Troubleshooting	13
Drive Unit Models H075 and H085 - Specifications	14
Hydraulic Motor Models H075 and H085 Exploded View and Parts List	15
Hydraulic Motor Models H075 and H085 Service Procedures.....	16-20
Planetary Exploded View & Parts List	21
Planetary Service Procedures.....	22-23
Accessories & Auger Replacement Wear Parts	24

Congratulations on the purchase of your PREMIER Hydraulic Earth Auger Attachment.

You have invested in a quality piece of equipment backed by people with years of experience. But only by proper installation, operation, and maintenance can you expect to receive the dependable performance and long life for which the earth auger was designed.

This operator's manual contains information regarding the installation, operation, safe use, and maintenance of your Premier Hydraulic Earth Auger Attachment. ***Please be sure all operators study this manual carefully and keep it on file for future reference.***

After reading this manual, if you have any questions about your Premier Hydraulic Earth Auger Attachment please contact us immediately as follows:

Toll Free: (866) 458-0008
Local: (260) 456-8518
Fax: (260) 456-6868
Web: www.premierauger.com
E-Mail: contact@premierauger.com

Premier Auger strives to provide superior products and the highest level of customer service. If you have any suggestions on how we can improve for the future, we would appreciate hearing from you.

Thank you for putting your trust in PREMIER.

PREMIER Hydraulic Augers, Inc.

2707 Lofty Drive
Fort Wayne, IN 46808

PREMIER HYDRAULIC AUGERS WARRANTY REGISTRATION

Date of Purchase: _____

Model #: _____ Serial #: _____

Owner Information:

Owner's Name _____ Phone _____

Company Name _____

Address _____

City _____ State _____

Zip Code _____ Country _____

Dealer Information:

Dealer Salesman _____ Phone _____

Dealer Name _____

Address _____

City _____ State _____

Zip Code _____ Country _____

Installation & Application Information:

This Premier Hydraulic Earth Auger will be mounted on: _____

This Premier Hydraulic Earth Auger Attachment has been accepted in good condition and I have been instructed by the dealer and/or read and understand the entire Operator's Manual for proper installation, proper and safe operation, preventative maintenance and service, warranty and all other information covered in the Operator's Manual. I also understand that all operators must read and understand the entire Operator's Manual.

Owners Signature _____

This page must be returned within 10 days of purchase to validate warranty.

Return To: Premier Hydraulic Augers, Inc.
2707 Lofty Drive
Fort Wayne, IN 46808

PREMIER HYDRAULIC AUGER WARRANTY POLICY

Model # _____ Serial # _____

Premier warrants its products to be free from defects in material or workmanship for a warranty period as stated below.

H095PD
✓

EARTH AUGER DRIVE UNITS MODELS H075PD & H085PD: 36 MONTHS
AUGER BITS & MOUNTINGS: 12 MONTHS

The warranty period begins on the date of purchase by the original purchaser.

Warranty Performance

To make a claim under this warranty, contact the dealer purchased from, who will then obtain written return authorization from Premier. All warranty returns must be accompanied by a Premier Auger's Return Authorization.

Remedy

During the applicable warranty period Premier Auger at its option will repair or replace, free of charge, any product determined by it to be defective. Such repair or replacement shall take place at a location designated by Premier Augers.

Exclusions From Warranty Coverage

1. This warranty automatically is void if any attempt is made to make field repairs to hydraulic motors or planetary gear reductions. To qualify for warranty performance the complete unit must be available for Premier Auger's inspection in its original "failed" condition.
2. There is no warranty against failures caused by or related to alterations or modifications made without the express written consent of Premier Auger.
3. Under no circumstances shall Premier Auger be responsible for the cost of labor for field replacement or repair, nor for damage caused by accident, misapplication, abuse, misuse, operator error, or environmental elements.
4. This warranty does not apply to parts subject to normal wear, such as auger teeth and points, nor to damage caused by the failure to perform recommended maintenance or to replace worn parts.
5. Under no circumstances shall Premier Auger be obligated for the cost of any repair or replacement by anyone other than Premier Auger, without its express written consent.

Limitations And Exclusions

This warranty is in lieu of all other warranties written or oral, express or implied, statutory or otherwise arising by operation of law, including any warranty of merchantability or fitness for purpose.

The liability of Premier Auger arising out of the supplying of any product covered by this warranty contract, negligence or otherwise shall not in any case exceed the cost of parts or labor required to rebuild or replace such defective product, together with the transportation costs attributable thereto. Upon the expiration of the applicable warranty period herein specified, all such liability shall terminate.









This warranty constitutes the entire warranty of Premier Auger, and no oral representations, warranties or guarantees by any agent of Premier Auger, or the seller shall be binding on Premier Auger, and no part of this warranty may be modified or extended except upon the express written consent of Premier Auger.

Improvements

Premier Auger continually strives to improve our products. Premier Auger reserves the right to make changes or additions to any product without incurring any obligation whatsoever to make such changes or additions to products previously sold.

SAFETY INFORMATION

THE USE OF THIS EQUIPMENT IS SUBJECT TO CERTAIN HAZARDS WHICH CANNOT BE PROTECTED AGAINST MECHANICAL MEANS OR PRODUCT DESIGN. ALL OPERATORS OF THIS EQUIPMENT MUST READ AND UNDERSTAND THIS ENTIRE MANUAL, PAYING PARTICULAR ATTENTION TO SAFETY AND OPERATING INSTRUCTIONS, PRIOR TO USING THE PREMIER AUGER HYDRAULIC EARTH AUGER. IF THERE IS SOMETHING IN THIS MANUAL YOU DO NOT UNDERSTAND, ASK YOUR SUPERVISOR TO EXPLAIN IT TO YOU. FAILURE TO OBSERVE THESE SAFETY PRECAUTIONS CAN RESULT IN DEATH OR SERIOUS INJURY OR SERIOUS EQUIPMENT DAMAGE.

-  All bystanders should be kept a minimum of 10 feet away from working area of the earth auger.
-  Always wear an OSHA approved hard hat and safety eye protection when operating or servicing this equipment. Do not wear loose fitting clothing, flopping cuffs, dangling neckties and scarves, or rings and wrist watches that can catch moving parts.
-  An operator must not use drugs or alcohol, which can alter his alertness or coordination. An operator taking prescription or over the counter drugs should seek medical advice on whether or not he can safely operate equipment.
-  Always locate underground electrical wires, telephone cables, and gas, water, and sewer lines before digging. Maintain safe clearance and avoid contact with any underground or overhead utility lines or electrically charged conductors.
-  Never alter or remove any safety decals or safety shields. Check this manual for location of these items and replace immediately if damaged or illegible.
-  Never adjust a relief valve for pressure higher than recommended by vehicle manufacturer.
-  Whenever changing or installing this or other attachments, make sure all connections are securely fastened.
-  Travel only with the earth auger in a safe transport position to prevent uncontrolled movement. Drive slowly over rough ground and on slopes. Tether earth auger with a chain, if necessary, to prevent uncontrolled swinging of earth auger when moving from hole to hole. Remove earth auger from vehicle when transporting to and from job site.
-  Before exiting the vehicle, lower earth auger to ground, turn off vehicle engine and lock vehicle breaks.

(continued)

SAFETY INFORMATION



Never check a pressurized system for leaks with your bare hand. Oil escaping from pin-hole leaks under pressure can penetrate skin and could cause serious infection. Hold a piece of cardboard up next to suspected leaks and wear a face shield or safety eye protection. If any fluid is injected into the skin, it must be removed immediately by a doctor familiar with this type of injury.



Before disconnecting hydraulic lines or fittings be sure to relieve all pressure by cycling all hydraulic controls after shutdown. Remember hydraulic systems are under pressure whenever the engine is running and may hold pressure after shutdown. Before applying pressure to the system make sure all connections are tight and that there is no damage to lines, fittings, and hoses.



Flow and pressure gauges, fitting, and hoses must have a continuous operating pressure rating of at least 25% higher than highest pressures of the system.



Avoid steep hillside operation, which could cause the vehicle to overturn. Consult your vehicle operator's and safety manuals for the maximum incline allowable.



Never perform any work on an earth auger unless you are authorized and qualified to do so. Always read the operator service manual before any repair is made. After completing maintenance or repair, check for correct functioning of the earth auger. If not functioning properly always tag "DO NOT OPERATE" until all problems are corrected.



This manual covers the safe use, installation, operation, and service instructions for the earth auger only. Always read the operating and safety manuals prepared for your vehicle and any other attachments before using them.

SKID STEER LOADER INSTALLATION INSTRUCTIONS

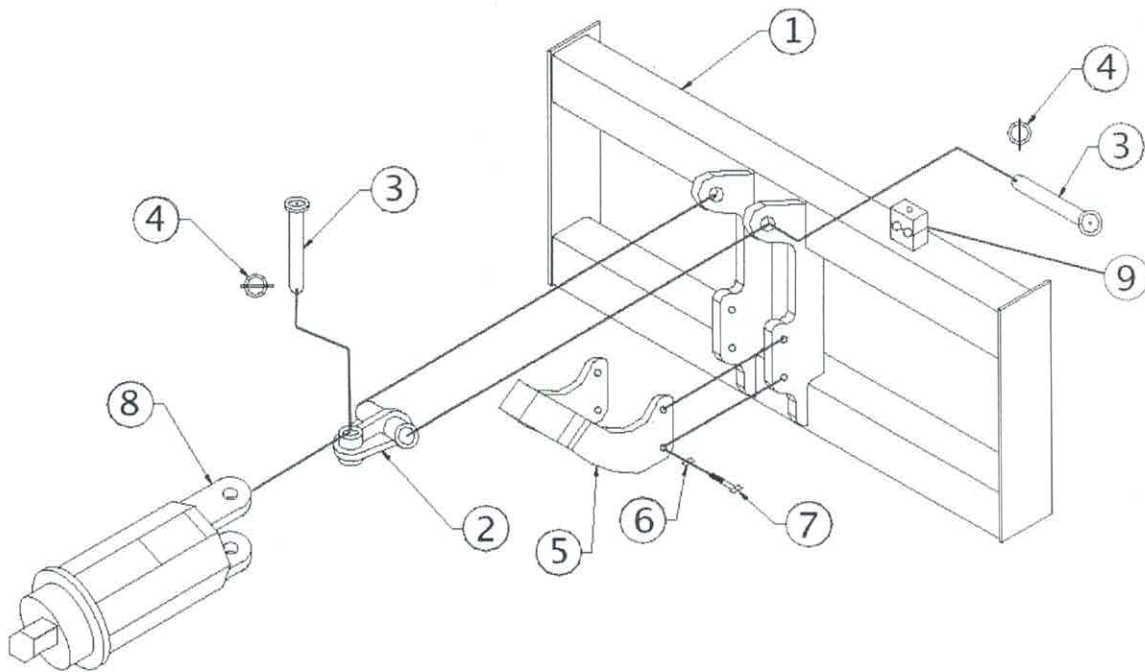

QUICK ATTACH MOUNTING BRACKET

<u>Ref.#</u>	<u>Part #</u>	<u>Description</u>
1	95000	Mount Weldment
2	91002	Knuckle Weldment
3	91001	Pin Weldment
4	40009	Snap Pin
5	91003	Carrier Weldment
6	40005	1/2\"-13 Nut
7	40006	1/2\"-13 HHCS 2-1/4\" Long
8	N/A	Drive Unit
9	40018	Hose Holder

- 1. READ AND UNDERSTAND ALL SAFETY INFORMATION BEFORE ATTEMPTING INSTALLATION.**
- Remove bucket or other attachment from vehicle quick attach mechanism.
- Assemble carrier weldment (5) to quick attach mounting bracket (1) with supplied 1/2\"-13 HHCS 2\" Long (7) and 1/2\"-13 (6) hex nut.
- Attach quick attach mounting bracket (1) to vehicle quick attach mechanism as per vehicle manufacturer's recommendations.
- Attach knuckle weldment (2) to the quick attach mounting bracket (1) with pin (3). Secure pin (3) with supplied snap clip (4).
- Attach and secure drive unit (8) to knuckle weldment (2) with pin (3). Secure pin (3) with supplied snap clip (4).
- Refer to the "Hydraulic System Hook-up" (page 11) in this manual for hydraulic connection instructions and recommendations.

BACKHOE & EXCAVATOR INSTALLATION INSTRUCTIONS

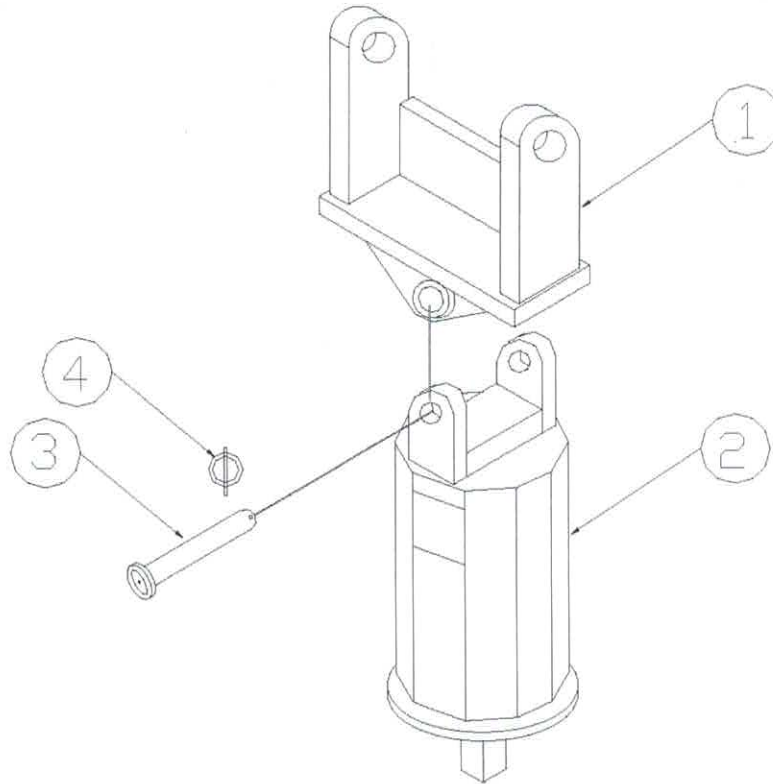

Ref.#	Part #	Description
1	(Varies by Host Machine)	Backhoe Mounting Bracket
2	(Varies by Host Machine)	Drive Unit
3	91001	Pin Weldment
4	40009	Snap Pin

1. **READ AND UNDERSTAND ALL SAFETY INFORMATION BEFORE ATTEMPTING INSTALLATION.**
2. Remove bucket from dipper arm and curl cylinder pin connections. The dipper arm pin will be used to attach backhoe mounting to backhoe dipper arm. Curl cylinder pin will not be required for earth drill installation.
3. Attach backhoe mounting bracket (1) to the dipper arm using the dipper pin removed from bucket in step #2. Secure bucket pin as per vehicle manufacturer's recommendation.
4. Attach drive unit (2) to backhoe mounting bracket (1) with pin weldment (3) and snap pin (4) supplied with drive unit.
5. Refer to the "Hydraulic System Hook-up" section in this manual for hydraulic connection instructions and recommendations.

HYDRAULIC SYSTEM HOOK-UP INSTRUCTIONS

1. Once the installation instructions are complete you are now ready to make the hydraulic connections necessary to operate your earth drill. **Read and understand safety information prior to making hydraulic connections.**
2. Your equipment dealer is in the best position to advise you as to where the best place on your machine is to make the hydraulic connections to power your earth drill drive unit. Some of the most common places to “tap” into the hydraulic system on various types of machines are as follows:

Skid Steer LoadersAuxiliary Hydraulic Outlets.
Backhoes & ExcavatorsAuxiliary Hydraulic Outlets or Bucket Curl Cylinder Outlet.
Wheel LoadersAuxiliary Hydraulic Outlets or Bucket Dump Cylinder Circuit.
3. Determine the length of hydraulic hoses required to plumb drive unit into the place on your machine where you will be “tapping” in to the hydraulics. Be sure the two hydraulic hoses are long enough to perform at the full range of the earth drills’ operating capacity.
4. Auger Drive Models H075PD and H085PD require two 3/4” I.D. hoses with #12 JIC female fittings on one end of each to connect hoses to drive unit fittings.
5. Once all hydraulic connections have been made and checked for leaks and proper hose lengths, you are now ready to operate your earth drill. **Read and understand operating instructions and safety information prior to operating your earth drill.**



WARNING! Hoses and Fittings must have a Continuous Operating Pressure Rating of at least 25% Higher than the Highest Pressures of the System that you are “tapping” into.

OPERATING INSTRUCTIONS

1. After all installation instructions have been completed, safety information read and understood and the rest of this operator's manual has been reviewed, your Hydraulic Earth Drill is now ready to use.
2. With the auger raised off the ground and the vehicle engine set at a low RPM, activate the earth drill control valve to determine position control valve lever must be in to turn auger in a forward (clockwise) rotation. This is the "digging" position.
3. Before beginning to dig, experiment with auger speed to determine a suitable auger RPM. Generally in light and sandy soil a high RPM is desirable. In hard, rocky, or frozen soils a slower RPM is desirable. To increase auger RPM, increase vehicle engine RPM. To decrease auger RPM, decrease vehicle engine RPM.
4. Return earth drill control valve to neutral position to stop the auger. Lower the auger to the ground so that only the center point penetrates the ground about 2".
5. Activate the earth control valve so auger is turning in a forward (clockwise) rotation. Use only enough down pressure to assure positive penetration of auger into the ground. Ease up on down pressure if auger rotation slows down drastically or stalls. Excessive down pressure will cause the auger to stall frequently.
6. When the auger has penetrated the ground about 24", raise the auger from the hole to clean the dirt out. Repeat this procedure until the desired hole depth is obtained.
7. Once the required hole depth is reached, allow the auger to turn a few seconds at this depth to clean the hole.
8. Return the earth drill control valve to the neutral position to stop the rotation of the auger. Raise the auger out of the hole, move away from the hole, then activate the earth drill control valve to spin the loose soil off of the augers.
9. If necessary, repeat steps 7 & 8 to obtain a cleaner hole.
10. In some soil conditions or when excessive down pressure is applied, auger may "screw" itself into the ground and become stuck causing earth drill to stall. If this happens, reverse the auger rotation (counter Clockwise) by moving the control valve lever to the reverse position and slowly raise the auger. Once the auger is unstuck, return the control valve lever to the forward position and continue digging.
11. If the auger becomes lodged under rocks, roots, or other large obstructions, do not attempt to raise auger out of the ground. See step 10 for proper procedure to relieve the auger.
12. Avoid excessive side loading to the earth drill which can cause drive unit or auger damage.
13. Keep auger teeth and points in good condition. Check frequently and always keep spares on hand so they can be replaced as wear is detected to avoid damage to tooth holders and auger flighting.

MAINTENANCE INSTRUCTIONS

1. **CLEAN HYDRAULIC OIL IS ESSENTIAL!** 80% of all hydraulic component failures are caused by contamination of the hydraulic oil. Always keep all dirt and other contaminants from entering hydraulic system during disconnect and connect operations. Always use dust caps and plugs on all quick disconnects when not in use. Tightly cap all hydraulic openings to hold oil in and keep dirt and other contaminants from entering hydraulic systems.
2. **CHECK ALL HYDRAULIC OIL DAILY FOR CONTAMINATION.** If contamination is present, determine the source of the problem.
3. **INSPECT ALL HYDRAULIC HOSE ASSEMBLIES DAILY** for cracked and brittle covers caused by excessive heat. Reduced viscosity of hydraulic oil occurs at higher operating temperatures and causes a breakdown of fluid additives such as wear inhibitors. Excessive heat will cause higher internal leakage in drive unit motor to become brittle and crack. Replacement of hoses before failure will prevent loss of hydraulic oil, time consuming "bleeding" of system, hydraulic oil contamination, and component damage caused by cavitations. It will also reduce the chance of personal injury caused by hydraulic fluid.
4. **CHECK AUGER DAILY** for loose, worn or broken cutting teeth and point. Worn teeth or point can drastically affect auger penetration and greatly reduce auger life expectancy. Always keep spare teeth and points on hand. Some digging conditions may require checking teeth and point at more frequent intervals.
5. **CHECK DRIVE UNIT AND ALL ACCESSORIES DAILY** for loose, bent, cracked, or worn, bolts and fasteners. Always use grade 5 or better replacement bolts. Always use lock washers with standard hex nuts or self locking nuts.
6. **CHECK ALL CONNECTING PINS DAILY** for bends, cracks, breaks, or wear. Replace if any of these conditions exist.
7. **CHECK DRIVE UNIT OUTPUT SHAFT DAILY** for bends, cracks, breaks, or wear. Replace if any of these conditions exist.
8. **CHANGE PLANETARY GEAR REDUCTION OIL AFTER FIRST 50 HOURS OF OPERATION, THEN EVERY 1000 HOURS OR IN ONE YEAR, WHICHEVER COMES FIRST.** Use mild extreme pressure lubricant API-GL-5 number 80 or 90 for filling planetary gear reduction under normal temperature ranges between 0 degrees and 120 degrees. Approximate oil capacity for models H075PD and H085PD is **four (4) quarts**. ***Check oil level daily to assure proper lubrication is maintained.***
9. When storing Drive Unit for any length of time be sure Drive Unit motor and hoses are full of clean oil. Also, be sure that Planetary Gear Reduction is full to the recommended capacity for each model as outlined in number 8 above.
10. Drive Unit output shaft, inside of Auger Collar, Variable Auger Extension shaft, inside of Variable Auger Extension Collar and all Connecting Pins should be coated liberally with grease as required to prevent rust and reduce wear.
11. Once paint has been worn off auger, coat liberally with grease as required, to prevent rusting.
12. Check Planetary Gear oil as follows. Lie Drive Unit horizontal with ground place bottom drain plug straight up. Remove plug, tilt drive unit at 2:00 or 10:00. Fill until oil leaks out from hole at one of these positions.

TROUBLESHOOTING

Problem	Possible Cause	Solution
Slow Speed	Low flow	Check Flow Meter. If low, investigate the cause.
	Line restrictions	Clear lines.
	Fittings or connections too small	Replace with proper sizes.
	Oil filter dirty	Replace.
	Hydraulic pump worn or damaged	See Dealer for repair.
Insufficient Digging Power	Worn Teeth Or Point	Replace.
	Low System Pressure	Check Pressure Gauge. If low, investigate cause.
	Relief Valve damaged or setting wrong	Adjust or replace as required.
	Excessive Load	Reduce load to within machine specifications.
Reverse Direction	Hoses Reversed	Re-install hoses correctly.
Excessive Oil Heating	Line Restrictions	Clear lines.
	Fluid Dirty	Replace hydraulic fluid & filter.
	Insufficient amount of hydraulic fluid	Fill reservoir to proper level. Increase reservoir storage capacity.
Oil Leaks	Hoses loose or damaged	Tighten or replace.
	Fittings loose or damaged	Tighten or replace.
	Hydraulic motor seals worn or damaged	See dealer for repair.

For further assistance, please call your dealer, or contact our sales department as follows:

Toll Free: 866-458-0008
Local: 260-456-8518
Fax: 260-456-6868

DRIVE UNIT MODELS H075PD AND H085PD SPECIFICATIONS

MODEL H075PD

Max. Auger Diameter48"
 Min. Hydraulic GPM30 gpm
 Max. Hydraulic GPM60 gpm
 Max. Hydraulic PSI4500 psi

No Case Drain Line Required
2-1/2" Hex Output Shaft
3 Year Warranty

<u>GPM</u>	<u>RPM</u>	<u>PSI</u>	<u>TORQUE</u>
40	43	3000	8527
45	49	3500	9948
50	54	4000	11369
60	65	4500	12790

MODEL H085PD

Max. Auger Diameter48"
 Min. Hydraulic GPM30 gpm
 Max. Hydraulic GPM60 gpm
 Max. Hydraulic PSI3500 psi

No Case Drain Line Required
2-1/2" Hex Output Shaft
3 Year Warranty

<u>GPM</u>	<u>RPM</u>	<u>PSI</u>	<u>TORQUE</u>
40	54	2500	8957
45	39	3000	10748
50	43	3500	12539
60	51		

Output speed and torque specifications are based on theoretical values and are provided for comparative purposes only. Premier Auger is continually striving to improve its products. Therefore, we reserve the right to make changes to our products or specifications at any time without notice or obligation.

HYDRAULIC MOTOR - MODELS H075PD AND H085PD & H095PD

EXPLODED VIEW & PARTS LIST

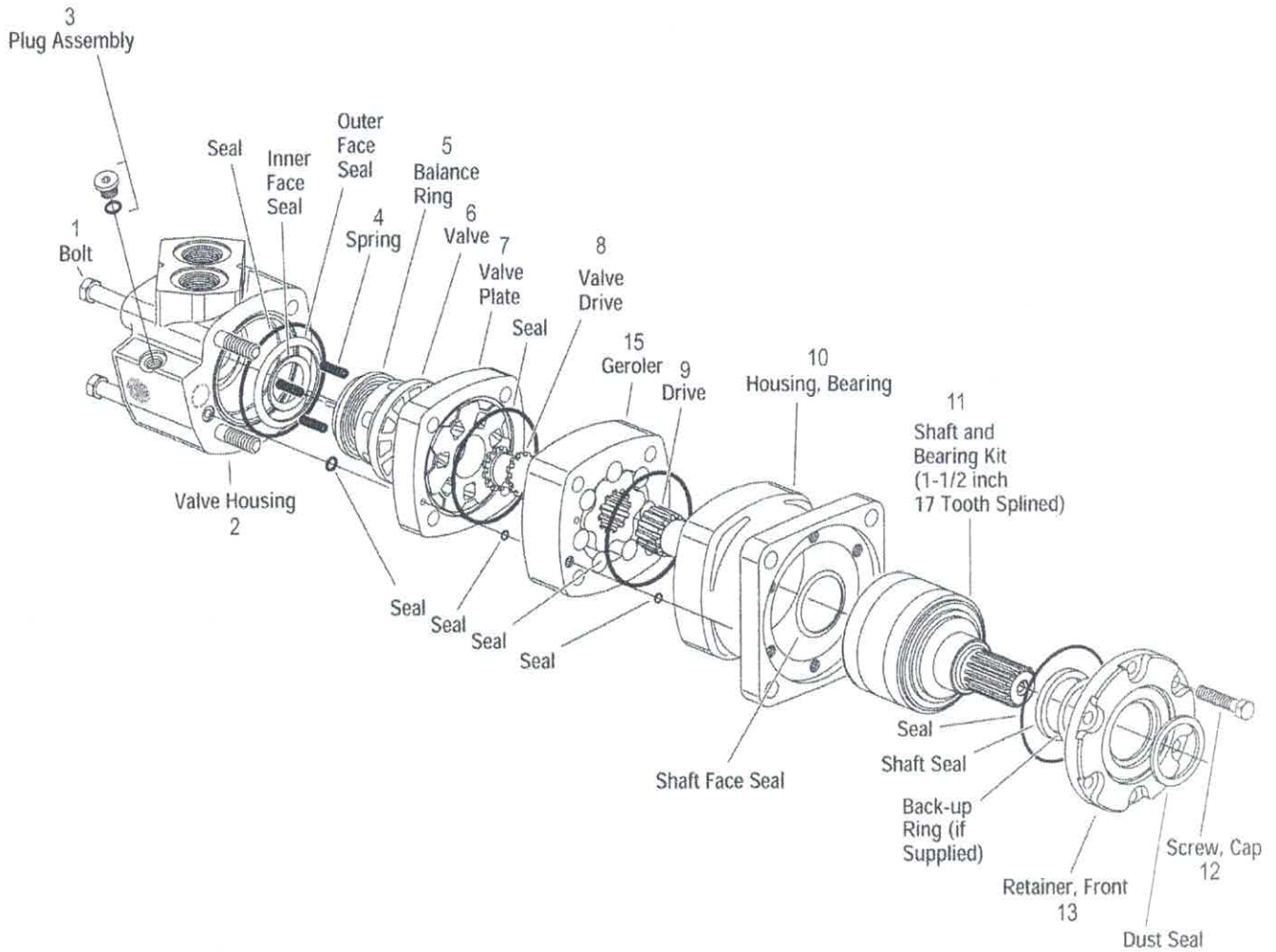

<u>Ref.#</u>	<u>Part#</u>	<u>Description</u>	<u>Quantity Required</u>
1.....		Bolt	4
2.....		Valve Housing	1
3.....		Plug Assembly	2
4.....		Spring	3
5.....		Balance Ring	1
6.....		Valve	1
7.....		Valve Plate.....	1
8.....		Valve Drive	1
9.....		Drive	1
10.....		Housing, Bearing.....	1
11.....		Shaft and Bearing Assembly	1
12.....		Cap Screw	6
13.....		Retainer, Front.....	1
14.....	62613	Seal Kit, Includes All Seals Listed	1
15.....		Geroler Set - Model H075PD	1
15.....		Geroler Set - Model H085PD	1
	60016	MOTOR MODEL H075PD	
	60051	MOTOR MODEL H085PD	
	60020	MOTOR	

(15)

HYDRAULIC MOTOR - MODELS H075PD AND H085PD

SERVICE PROCEDURES

DISASSEMBLY

Cleanliness is extremely important when repairing a hydraulic motor. Work in a clean area. Before disconnecting the lines, clean port area of motor thoroughly. Use a wire brush to remove foreign material and debris from exterior joints of motor. Check shaft and keyway, use 600 grit paper/cloth to remove all nicks, burrs, and sharp edges that might damage the shaft seals when installing retainer on shaft and bearing assembly. Before starting disassembly procedures, drain oil from inside of motor.

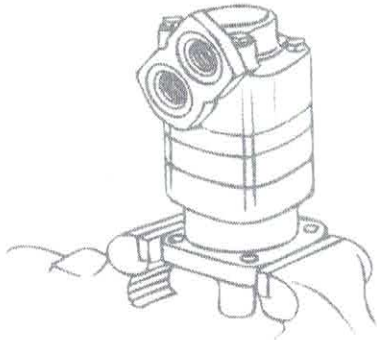

Figure 1

1 Place motor in a vise with output shaft down. Clamp across edge of bearing housing not on housing (see Figure 1). Excessive clamping pressure on housing will cause distortion. When clamping, use some protective device on vise, such as special soft jaws, pieces of hard rubber or board.

Although not all drawings show the motor in a vise, we recommend that you keep the motor in the vise during disassembly. Follow the clamping procedures explained throughout the manual.

2 Remove 4 bolts (or nuts for earlier models) from motor. Remove studs (earlier models) as shown in step 16.

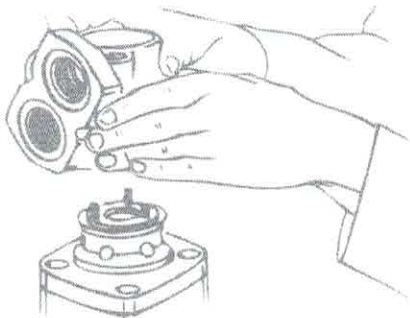

Figure 2

3 Lift valve housing straight up. If done carefully, the springs and balance ring subassembly will remain on valve for easy removal.

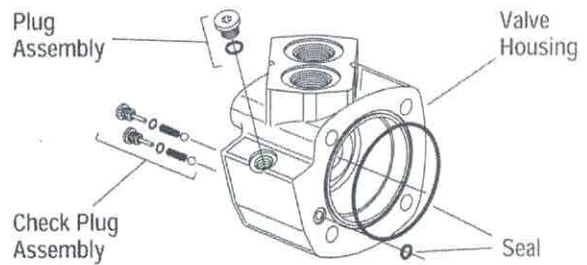

Figure 3

4 Carefully remove the following from the valve housing:

- 1 seal, 92,3 mm [3.63 inch] I.D.
- 1 seal, 7,6 mm [.30 inch] I.D.
- 2 check valve plug assemblies (plug, seal, spring, ball) 1 plug (case drain) with seal.

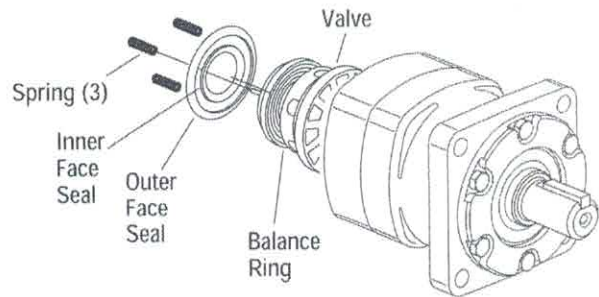

Figure 4

5 Remove 3 balance ring springs.

6 Remove balance ring subassembly.

7 Remove inner and outer face seals from the balance ring.

8 Lift off valve.

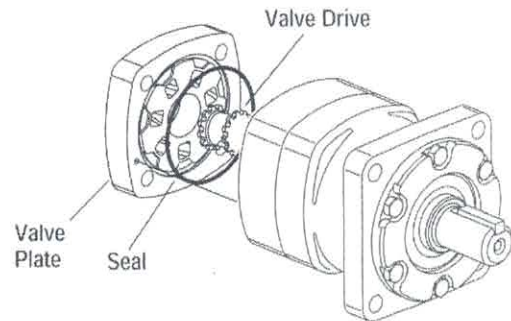

Figure 5

9 Remove valve plate.

10 Remove 95,0 mm [3.74 inch] I.D. seal from valve plate (see Figure 5).

11 Remove valve drive (see Figure 5).

HYDRAULIC MOTOR - MODELS H075PD AND H085PD SERVICE PROCEDURES

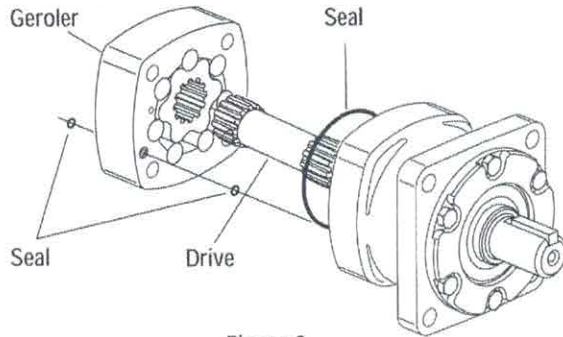

Figure 6

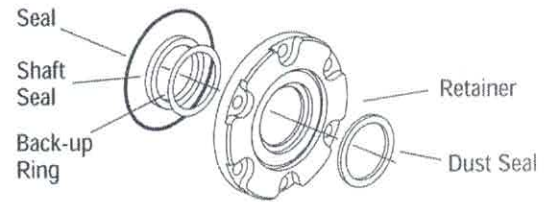

Figure 9

12 Remove Geroler. Retain rollers in outer Geroler ring if they are loose.

13 Remove 2 seals (6,1mm [.24 inch]) from Geroler, 1 seal on each side of Geroler.

14 Remove drive.

15 Remove 95,0 mm [3.74 inch] I.D. seal from bearing housing.

16 Use a stud remover or vise grips to remove studs (earlier models only). Then clamp bearing housing in vise as shown in Figure 7. Loosen 6 bolts. Then remove bolts and retainer. You may have to pry retainer free but do not damage housing or retainer.

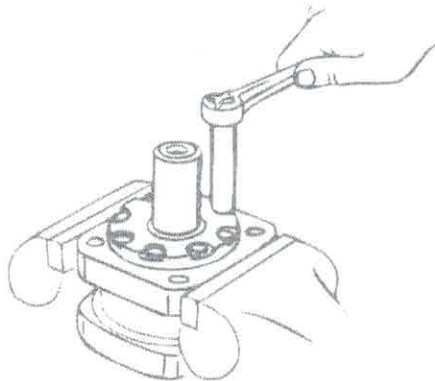

Figure 7

17 Remove 92,3 mm [3.64 inch] I.D. seal, shaft seal and back-up ring (if supplied) from retainer. Use a small screwdriver to remove dust seal. Do not damage bore of retainer.

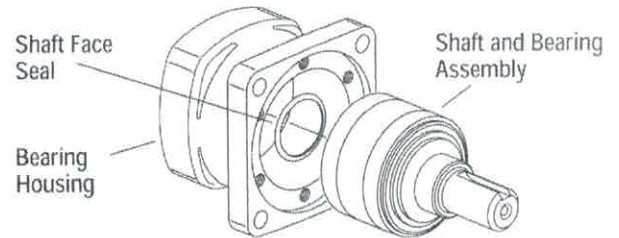

Figure 10

18 Remove shaft and bearing assembly. You may need a press to remove shaft and bearing assembly (see Figure 10).

19 Remove shaft face seal from bore of bearing housing (see Figure 10). Do not damage bore of bearing housing.

Note: Individual parts of the shaft and bearing assembly are not sold separately and must be replaced as a unit.

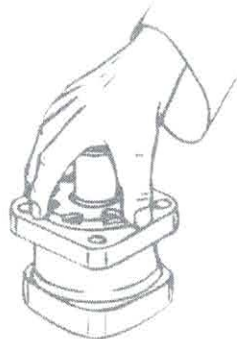

Figure 8

HYDRAULIC MOTOR - MODELS H075PD AND H085PD

SERVICE PROCEDURES

REASSEMBLY

Check all mating surfaces. Replace any parts that have scratches or burrs that could cause leakage. Clean all metal parts in clean solvent. Blow dry with air. Do not wipe with cloth or paper towel because lint or other matter could get into the hydraulic system and cause damage. Do not use a coarse grit papers/cloth or try to file or grind motor parts. Check around the keyway and chamfered area of the shaft for burrs, nicks, or sharp edges that can damage the seals when reassembling the retainer.

Note: Lubricate all seals (prior to installation) with petroleum jelly such as Vaseline®. Use new seals when reassembling the motor. Refer to parts list (6-127 6000 Series -005 and 6-159 6000 Series -006) for replacement parts and proper kit number.

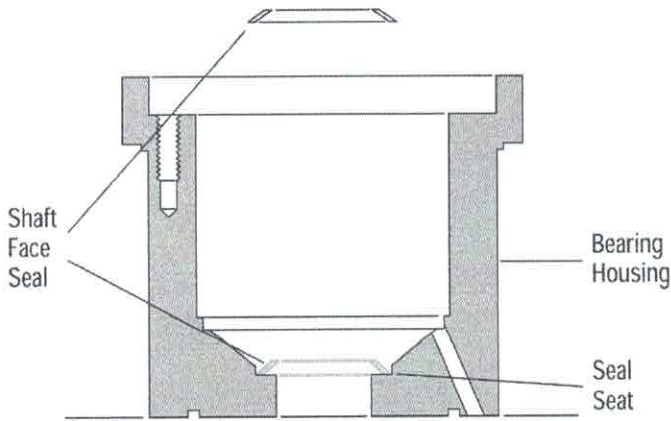

Figure 11

20 Place bearing housing on smooth flat surface with largest open end of housing up.

Apply petroleum jelly to shaft face seal. Install seal in seal seat. Seat seal properly in groove (see Figure 11 and 14). A damaged or improperly installed shaft face seal could cause internal lubrication loss and subsequent parts wear.

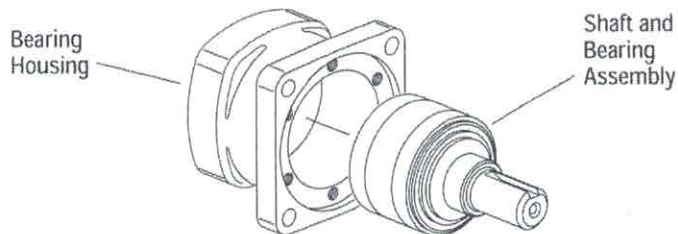

Figure 12

21 Install shaft and bearing assembly in bearing housing (see Figure 12). Do not damage seal in bore of housing. You may need a press to install shaft and bearing assembly.

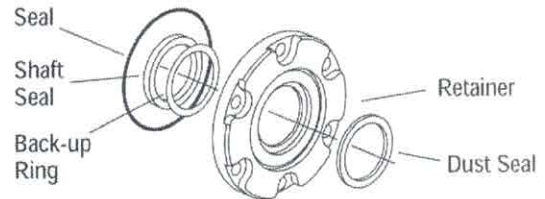

Figure 13

22 Use a small press, if available, to install dust seal in retainer. Metal side of dust seal must face toward retainer as shown in Figure 14. If a press isn't available, use a plastic or rubber hammer to tap dust seal in place.

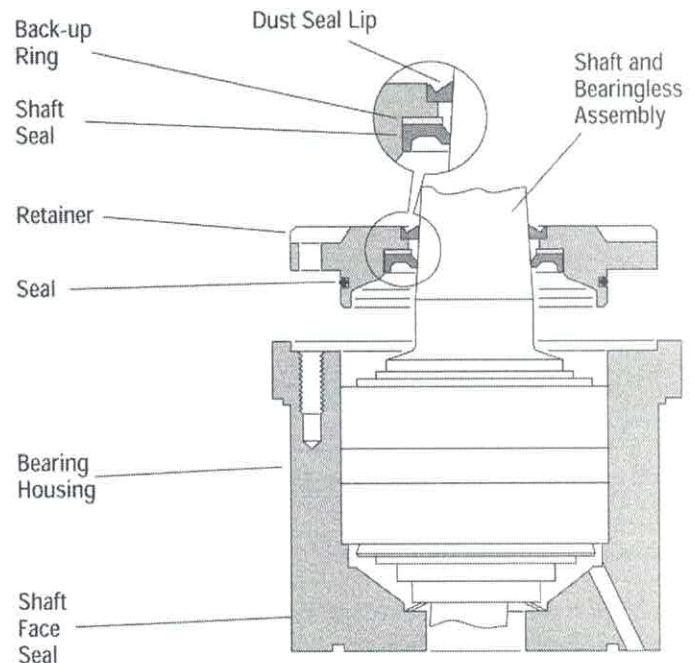

Figure 14

23 Install 92,3 [3.64] I.D. seal, back-up ring and shaft seal in retainer. Flat or smooth side of shaft seal must face toward retainer as shown in Figure 14. Apply petroleum jelly to inside diameter of shaft seal (after installing seal).

24 Before installing retainer, place a protective sleeve of bullet (see note below) over shaft. Grease inside diameter of dust and shaft seals. To prevent damage to seals, install retainer over shaft with a twisting motion. Do not cut or distort shaft seal. Damage to shaft seal will cause external leakage.

Note: Bullet 600464 for 1-1/2 inch diameter shafts available—by special order through our service department.

HYDRAULIC MOTOR - MODELS H075PD AND H085PD

SERVICE PROCEDURES

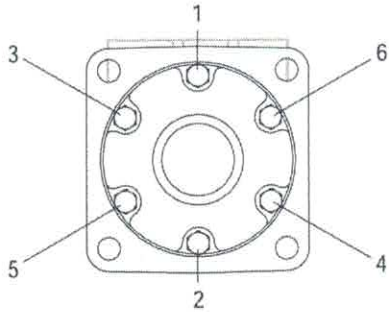

Figure 15

25 Lubricate threads of 6 bolts with a film of light oil. Install and finger tighten all 6 bolts. Torque bolts to 6 Nm [50 lb-in] in sequence (see Figure 15). Then final torque to 34 Nm [300 lb-in], in sequence.

Note: Full torque 34 Nm [300 lb-in] on one bolt at a time can damage bolt or retainer.

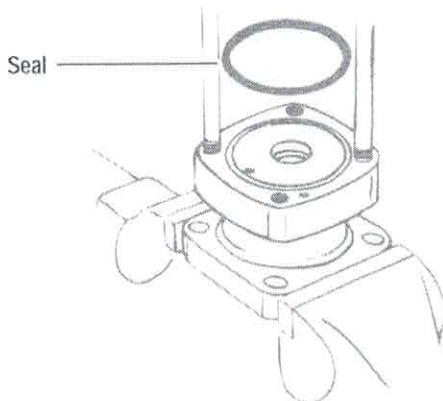

Figure 16

27 Reposition motor in vise with output shaft down. Clamp across edges of retainer as shown in Figure 16.

28 Pour a small amount of light oil inside the output shaft.

29 Install 2 studs (earlier models), diagonally opposed, in bolt holes of bearing housing (see Figure 16). If you replace studs with bolts, use 2 studs for alignment purposes when stacking parts.

30 Apply a light film of petroleum jelly on 95,0 mm [3.74 inch] I.D. seal. Install seal in bearing housing (see Figure 16).

31 Install drive in output shaft (insert longer splined end of drive first), (see parts drawing on page 3).

32 Apply petroleum jelly on 2 seals, 6,1 mm [.24 inch] I.D. Install seals (1 on each side of Geroler) in case drain grooves of Geroler.

Note: Installation at this point involves 3 steps in timing the motor. Timing determines the direction of rotation of the output shaft.

Timing parts include:

1. Geroler
2. Valve drive
3. Valve Plate
4. Valve

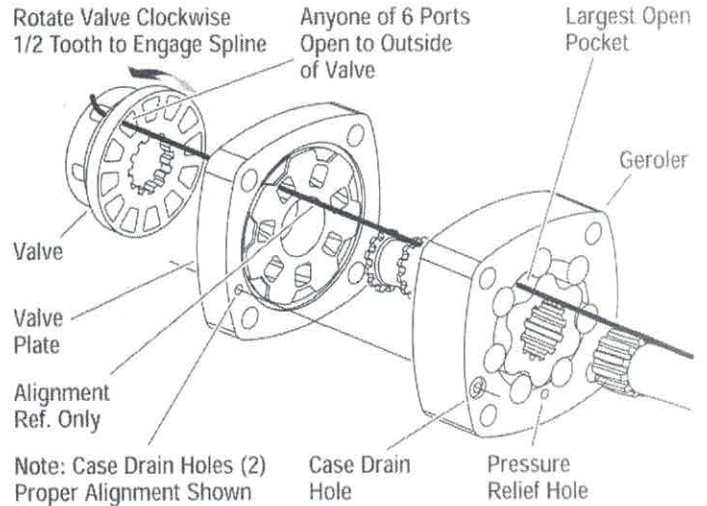

Figure 17 Timing Alignment

Timing Step No. 1 — Locate largest open pocket in Geroler. Then mark location of pocket on outside edge of Geroler (see Figure 17).

33 Align case drain hole and pressure relief hole in Geroler with case drain hole and pressure relief hole in bearing housing. Install Geroler on bearing housing (see Figure 17). Retain rollers in outer Geroler ring if they are loose.

34 Install valve drive in Geroler.

35 Apply a light film of petroleum jelly on 95,0 mm [3.74 inch] I.D. seal. Install seal in valve plate.

36 Align case drain hole in valve plate with case drain hole in Geroler. Install valve plate (seal side toward Geroler) on Geroler as shown in Figure 17.

Timing Step No. 2 — Locate slot opening in valve plate which is in line with largest open pocket of Geroler (see Figure 17).

37 Use the following procedure for installing the valve on the valve plate.

Timing Step No. 3 — Locate any one of the side openings of the valve that goes through to the face of the valve. Line up this side opening in the valve with open slot of valve plate that is in line with largest open pocket of Geroler. Rotate valve clockwise (1/2 spline tooth) to engage valve with the valve drive spline, alignment reference shown in Figure 17 (above). This procedure provides standard timing when pressurized as shown in Figure 18 (below).

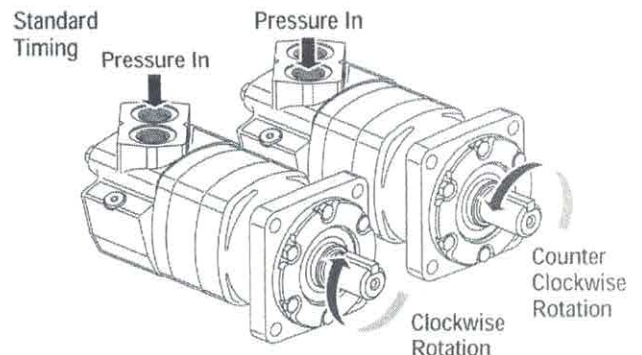

Figure 18

HYDRAULIC MOTOR MODELS H075PD AND H085PD

SERVICE PROCEDURES

38 Apply clean grease on 3 balance ring assembly springs. Install springs in 3 holes located inside bore face of valve housing (see Fig. 19).

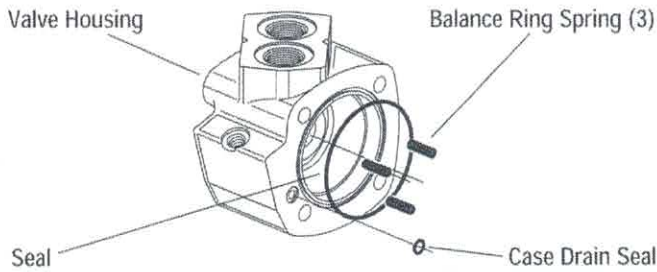

Figure 19

39 Apply a light film of petroleum jelly on 7,6 mm [.30 inch] I.D. seal. Install seal in case drain groove of valve housing.

40 Apply a light film of petroleum jelly on 92,3 mm [3.63 inch] I.D. seal. Install seal in outside seal groove of valve housing.

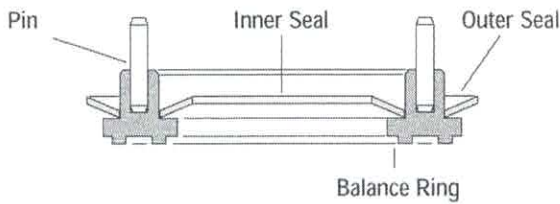

Figure 20

41 Apply petroleum jelly on inner and outer face seals. Install seals on balance ring as shown in Figure 20.

Important: Install face seals in the positions shown in Figure 20 or the motor will not operate properly. Do not force or bend these face seals. Any damage to these seals will affect the operation of the motor.

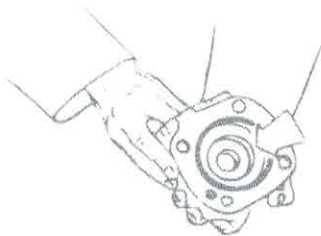

Figure 21

42 Align balance ring assembly pins with 2 holes in valve housing (see Figure 21). Install balancing ring subassembly in valve housing.

43 Insert your finger through port of housing. Apply pressure to side of balance ring assembly. Hold ring in position until valve housing is in place (see Figure 21). Align case drain hole in housing with case drain hole in valve plate. Install valve housing against valve plate (see Figure 22).

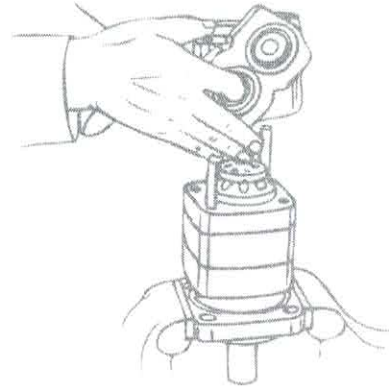

Figure 22

Note: After installing valve housing on valve plate, check between body parts of motor for unseated seals.

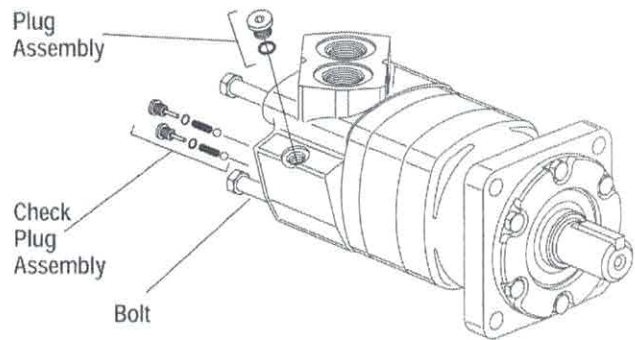

Figure 23

44 Install and finger tighten 2 bolts (or studs for earlier models) opposite alignment studs. Remove alignment studs and install remaining bolts (or studs and 4 nuts for earlier models). Torque bolts (or nuts) to 98 Nm [864 lb-in/ 72 lb-ft], in sequence (see Figure 24).

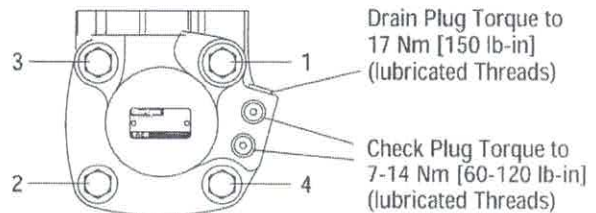
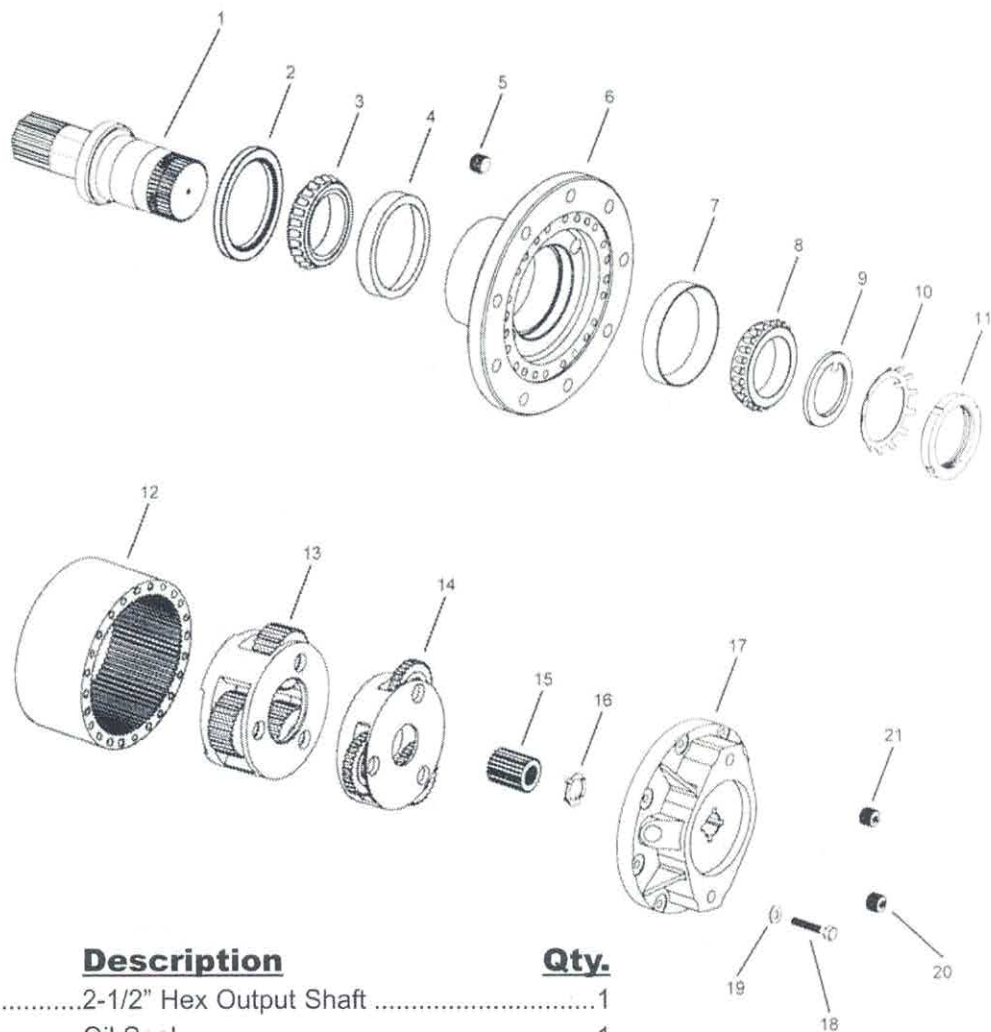

Figure 24

45 Install 2 check plug assemblies (ball, spring, plug with seal). Also install case drain plug with seal, parts shown in Figure 23 and plug torque shown in Figure 24.

PLANETARY - MODELS H075PD AND H085PD & H095PD EXPLODED VIEW AND PARTS LIST



<u>Ref.#</u>	<u>Part #</u>	<u>Description</u>	<u>Qty.</u>
1		2-1/2" Hex Output Shaft	1
2	69021	Oil Seal	1
3		Bearing Cone	1
4		Bearing Cup	1
5		Pipe Plug	1
6		Hub	1
7		Bearing Cup	1
8		Bearing Cone	1
9		Thrust Washer	1
10	69708	Lock Washer	1
11	69709	Bearing Nut	1
12		Ring Gear	1
13		Secondary Carrier Assembly	1
14		Primary Carrier Assembly	1
15		Primary Sun Gear	1
16		Thrust Washer	1
17		Cover	1
18		Hex Head Bolt (Grade 8)	24
19		Flat Washer	24
20		Magnetic Plug	1
21		Pipe Plug	1

65013 Planetary 2 1/2" hex shaft
 62615 SHAFT SEAL KIT (21)

PLANETARY - MODELS H075PD AND H085PD SERVICE PROCEDURES

IDENTIFICATION

IMPORTANT: All Power Wheel units and kits are shipped with a nameplate that includes the Auburn Gear part number and order code as shown.

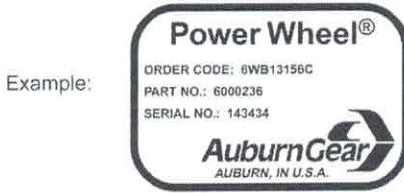

In addition to the nameplate, Power Wheel drives are stamped with an identification number which appears on the cover or hub flange as shown.

Example: **6000236-A-4-9**

When ordering parts, the information included on the nameplate or the stamped identification number is necessary to accurately identify the drive and obtain the correct replacement parts. Once this information has been obtained, contact Auburn Gear for the appropriate parts list.

DISASSEMBLY OF POWER WHEEL

STEP 1

Remove twentyfour hex head bolts (18) and flat washers (19) from cover (17). Lift cover (17) from assembly. Thrust washer (16) usually remains with cover (17).

STEP 2

Lift sun gear (15) from primary carrier assembly (14).

STEP 3

Remove primary carrier assembly (14).

STEP 4

Remove the secondary carrier assembly (13). It may be necessary to remove the ring gear (12) first, if difficulty is encountered in removing the carrier assembly (13).

STEP 5

If not previously removed (see step 4) remove ring gear (12) from hub(6). It may be necessary to strike ring gear (12) with a rubber mallet to loosen from hub (6).

STEP 6

One tab of lock washer (10) will be engaged in the slot of bearing nut (11); bend back to release. Remove the bearing nut (11), lock washer (10) and thrust washer (9). **Note:** A special locknut wrench, 593RR, is required for the removal of the bearing locknut. Contact Auburn Gear for procurement of wrench and other service tools.

STEP 7

Bolt spindle/shaft drive tool, 598FF, to hub (6). Drive output shaft (1) from hub (6) by turning bolt in center of spindle/shaft drive tool. Care should be taken to avoid damaging splines and threads on output shaft. **Note:** Bearing cone (8) has been designed with a press fit with respect to output shaft (1). Considerable force will be required to remove cone from shaft.

STEP 8

Remove oil seal (2) and bearing cones (3 & 8) from hub (6). Inspect bearing cups (4 & 7) in hub (6) and remove only if replacement is required.

ASSEMBLY OF POWER WHEEL

STEP 1

Press new bearing cups (4 & 7) into each side of hub (6). It is recommended that bearing cups (4 & 7) and cones (3 & 8) be replaced in sets.

STEP 2

Assemble bearing cone (3) into cup (4) at seal end of hub (6) and press a new seal (2) into hub (6).

STEP 3

Lubricate lips of oil seal (2) and lower hub (6) onto output shaft (1). Keep hub (6) centered to prevent damage to oil seal (2).

STEP 4

Assemble bearing cone (8) over output shaft (1). Press bearing cone (8) over output shaft bearing journal using press and cylindrical bearing cone driver 598F. Press bearing cone (8) down until rollers just touch cup (7). Take care to avoid pressing cone (8) too far. **Note:** If a press is not available, place tool 598F over splined end of output shaft (1) on the edge of bearing cone (8) and drive into place with hammer or mallet. If this method is used, care must be taken to avoid damage to bearing cone and spindle.

STEP 5

Install thrust washer (9) and bearing nut (11). **DO NOT install lock washer (10) at this time.**

STEP 6

Place spindle/shaft drive tool, 598FF, over output shaft (1) and bolt or pin to hub (6).

STEP 7

Check initial rolling torque by installing a lb.-in. torque wrench (arm or dial type) on center nut of spindle/shaft drive tool and turning hub (6) slowly and steadily with the torque wrench. Note mean torque. An initial bearing rolling torque of greater than 52 lb.-in. with boot seal installed or 48 lb.-in. without boot seal means that the cone (8) was pressed on too tightly in step 4. In this case, back off bearing cone (8) by pressing output shaft (1) out of cone (8) until initial preload is relieved. See step 7 of disassembly procedure.

STEP 8

Torque bearing nut (11) with bearing nut wrench 593RR until a bearing rolling torque of 44 - 52 lb.-in., with a boot seal installed, or 40 - 48 lb.-in., without a boot seal, is reached. This may require several trials of pressing the cone (8) by torquing the nut (11) and then checking the rolling torque. Rotate hub (6) by hand as nut is being tightened in order to seat bearings. **Note:** Up to 250 lb.-ft. of torque may have to be applied to bearing nut (11) in order to press cone (8) into position.

STEP 9

Remove bearing nut (11) and install lock washer (10). Replace bearing nut (11).

PLANETARY - MODELS H075PD AND H085PD SERVICE PROCEDURES

STEP 10

Re-torque bearing nut (11) to 65 - 75 lb.-ft. (88 - 100 Nm).

STEP 11

Secure bearing nut (11) by bending a lock washer (10) tab into one of four bearing nut slots. If no tab aligns with a slot, the nut may be tightened until one of the slots aligns with a lock washer tab.

STEP 12

Apply a bead of silicone sealant to face of hub (6) that mates with ring gear (12). See instructions on sealant package.

STEP 13

Assemble ring gear (12) to hub (6) being careful to align all the bolt holes.

STEP 14

Place secondary carrier assembly (13) into ring gear (12) aligning the gear teeth. Carrier splines mesh with splines on output shaft (1).

STEP 15

Lower primary carrier assembly (14) into assembly. Align sun gear teeth with secondary carrier planetary gears and primary planet gears with ring gear (12).

STEP 16

Install primary sun gear (15) into primary carrier assembly. Sun gear (15) should turn freely by hand when assembled.

STEP 17

Apply a bead of silicone sealant to cover face of ring gear (12). Secure thrust washer (16) with tangs engaged in cover (17). **Note:** Washer (16) can be secured to cover (17) with a small amount of grease or silicone sealant. Assemble cover (17) to ring gear (12). Align cover (17) with hub (6) such that pipe plug holes on cover (17) align with mounting holes in hub (6).

STEP 18

Install twentyfour 3/8-16 x 6 1/2 inch Grade 8 bolts (18) and flat washers (19) and torque to 45 - 50 lb.-ft. (61 - 67 Nm).

STEP 19

Position filler opening horizontally and fill unit to oil level hole in hub (6). Install pipe plugs (5), (20) and (21).

NOTE: When installing a hydraulic motor to the Power Wheel drive it is necessary to place an "O" ring or gasket (not supplied by Auburn Gear) between the motor and the planetary drive. "O" ring sizes: SAE A 2-042, SAE B 2-155, SAE C 2-159, SAE D 2-163. Apply sealant to motor mounting bolt threads when holes in cover are thru holes.

CARRIER ASSEMBLIES

It is recommended that the primary and secondary carrier assemblies (13 & 14) be serviced in their entirety to protect the integrity of the Power Wheel drive.

LUBRICATION RECOMMENDATIONS

IMPORTANT: POWER WHEEL PLANETARY DRIVES ARE SHIPPED WITHOUT LUBRICANT AND MUST BE FILLED TO THE PROPER LEVEL PRIOR TO START UP.

Observe lubrication recommendations given by the original equipment manufacturer. When specific recommendations are not available, use mild extreme pressure lubricant API-GL-5, No. 80 or 90 when filling the Power Wheel under normal temperature ranges between 0 - 120°F (-18 to 49°C). Power Wheel is to be half full of oil when unit is mounted level and horizontal. Use drain and fill plugs located in cover. Oil is to be changed after first 50 hours of operation with subsequent changes every 1000 hours or yearly, whichever comes first. If unit is to be operated vertically, if ambient conditions are outside the specified range, or if the oil temperature exceeds 200°F (93°C) contact Auburn Gear for oil and level recommendations.

STORAGE

A protective film is applied to the Power Wheel at the factory to prevent rust during shipment. Additional protection may be required if the Power Wheel is to be stored for an extended period of time.

SEALING COMPOUND

Silastic RTV732 sealer and General Electric Silimate RTV No. 1473 or RTV No. 1503 are recommended for sealing gasket surfaces. Sealant should be applied in a continuous bead, which should be centered on the surface to be sealed but should move to the inside of the hole at each bolt hole location. For service requirements order Auburn Gear part number 604101.

SPECIFICATIONS

Maximum intermittent output torque	130,000 lb. in. (14,690 Nm)
Maximum input speed	5,000 RPM
Oil capacity	50 oz (1,478ml)

ACCESSORIES & AUGER REPLACEMENT WEAR PARTS

CONSTRUCTION AUGER TEETH

Wisdom Tooth	#00200
Chisel Tooth	#00201
Wisdom Gage Tooth.....	#00202
Hardfaced Wisdom Tooth.....	#00205
Hardfaced Chisel Tooth	#00206
Hardfaced Wisdom Gage Tooth.....	#00207
Carbide Wisdom Tooth.....	#00208
Carbide Chisel Tooth	#00209
RB Carbide Wisdom Tooth.....	#00237
Tooth Pocket for CDC Augers	#00225
Rock Auger Bullet Tooth.....	#00221
Bullet Tooth Holder.....	#00223
5/8"-11 Carriage Bolt 1-1/2" Long	#40000
5/8"-11 Lock Nut.....	#40001



Gage Tooth



Wisdom Tooth



Chisel Tooth



Rock Auger
Bullet Tooth

CONSTRUCTION AUGER PILOT POINTS

Fishtail Point.....	#00203
Hardfaced Fishtail Point.....	#00210
Carbide Fishtail Point.....	#00211
4-1/2" Auger Fishtail Point	#00204
Square Drive Lug	#00105
4" Auger Drive Lug.....	#00106
CDR Rock Auger Pilot -	
- with 1-3/4" Square Shank	#00236
- with 2-3/8" API.....	#00222
CDR Rock Auger Bullet Tooth	#00221
CRB Rock Auger Fishtail Point	#00239



Fishtail Point



CRB Rock
Auger Fishtail
Point



CDR Rock
Auger Pilot

HOSES & FITTINGS

1/2" Hydraulic Hoses 68" Long	#61061
1/2" Hydraulic Hoses 108" Long	#61050
1/2" Hydraulic Hoses 120" Long	#61049
1/2" Female Flat Faced Coupler	#61006
1/2" Male Flat Faced Coupler	#61007
3/4" Hydraulic Hose Kit 108" Long	#61051
3/4" Female Flat Faced Coupler	#61043
3/4" Male Flat Faced Coupler	#61044

AUGER COLLARS

2" Hex Auger Collar	#00102
2-9/16" Round Auger Collar.....	#00101
2" Round Auger Collar	#00100
2-1/2" Hex Collar	#00103
2-5/8" Hex Collar	#00104

MISCELLANEOUS WEAR PARTS

Knuckle Pin	#91001
Drive Unit Housing.....	#91000